

5–11. Magnetic Pickup Gap (Figure 5–9)

NOTE: Unless otherwise directed by this manual, gap adjustment should be followed by phasing adjustment, paragraph 5–12.

1. Gain access to MPU by performing steps 1 through 4 of paragraph 5–27.
2. Remove covers per paragraph 5–18a.
3. Loosen screw slightly (1), until MPU (2) can be rotated using moderate force.
4. Set gap between MPU (2) and timing disk (3) using 0.010 inch flat feeler gauge (4).
 - (a) Check gap at 90 degree intervals through one complete rotation.
 - (b) If gap is less than 0.008 in, check that axle flats are at a 45 degree angle and readjust as required. Tighten screw (1). Verify MPU (2) does not rotate. Run a test print.

NOTE: Late production units may have countersinks instead of axle flats.

- (c) If extra dots appear after setting gap, increase gap by .001 and try again (but do not exceed .015).
- (d) If there are missing dots or no print after setting gap, decrease gap by .001 and try again. The nominal range is .009 to .011.

– CAUTION –

Do not operate printer if MPU can be rotated. Damage to timing disk and/or MPU will occur if MPU contacts the timing disk.

NOTE: Steps 5 and 6 below may be performed as an additional check if desired.

5. Connect oscilloscope between pin 2 of terminal strip (5) and chassis ground. Operate printer.
6. Verify amplitude of scope trace is between 2.0 and 3.5 Volts peak to peak and waveform is as shown in the figure. Verify the entire envelope (two resyncs) is smooth and consistent.

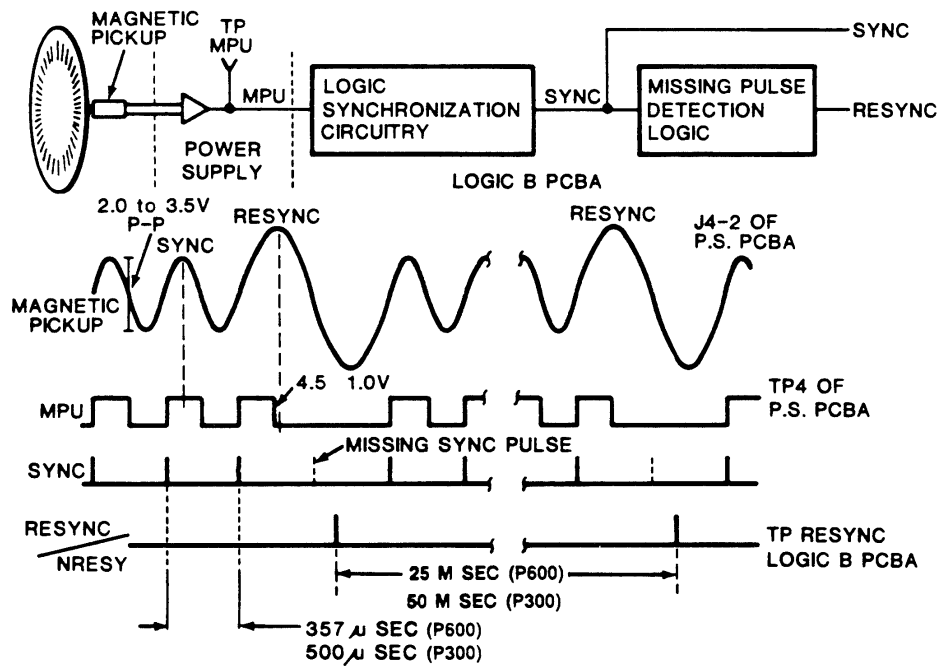
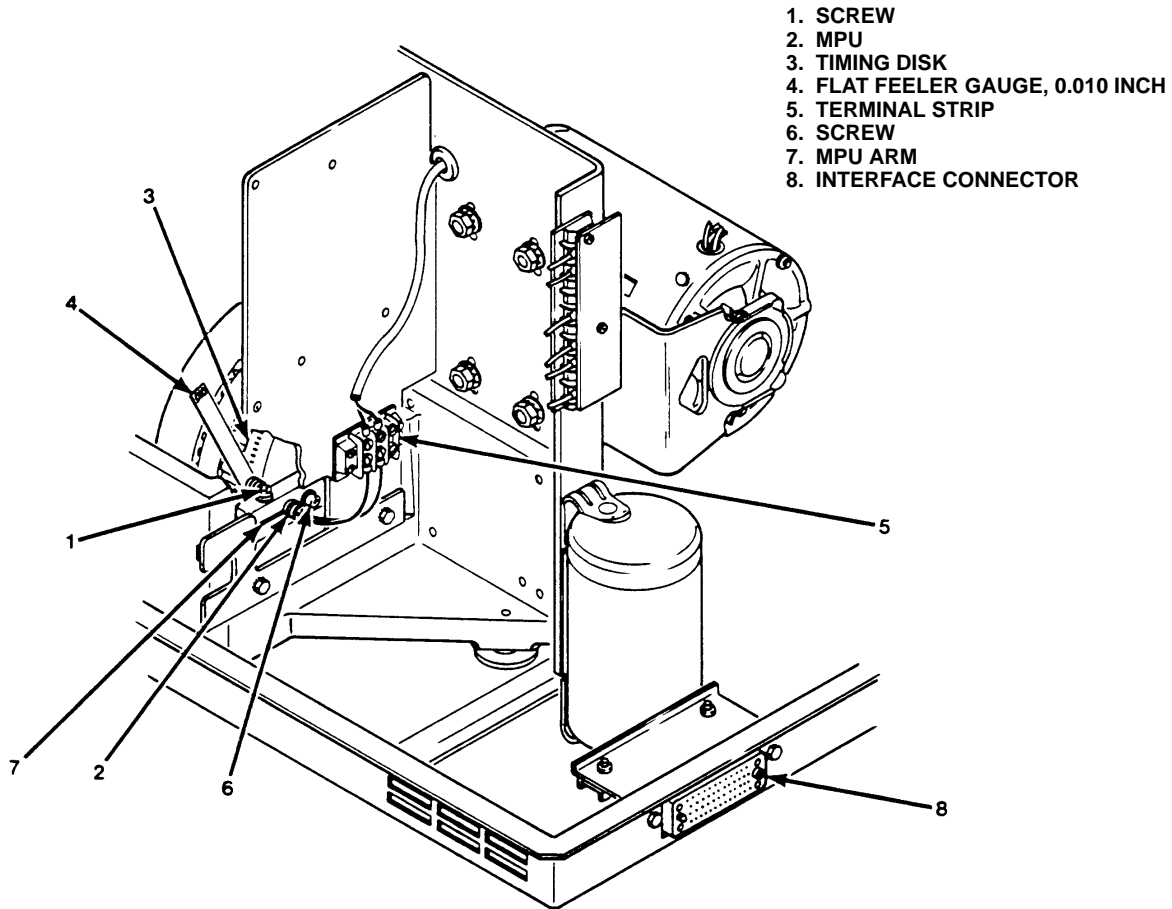

Figure 5-9. Magnetic Pickup Gap and Phasing Adjustment

5-12. Magnetic Pickup Phasing Adjustment (Figure 5-9)

NOTE: Unless otherwise directed by this manual, perform gap adjustment, paragraph 5-11 before proceeding.

1. Loosen screw (6) until MPU arm (7) can be pivoted, but only with some effort.
2. Load printer with 14 7/8-inch wide single-part paper.

NOTE: If exerciser is not available, use self-test Es or host computer to generate all Hs. Wide paper is required if using self-test.

3. Connect exerciser to printer interface connector (8).

NOTE: Exerciser will interface only with parallel Centronics or Dataproducts connectors.

4. Set exerciser controls as follows.

LINE LENGTH = 132

CHARACTER = H

SPECIAL = None

FUNCTION = LF

POLARITY = Low True if jumper W7 is installed on Logic A PCBA. High True if jumper W7 is not installed on Logic A PCBA.

5. Press ON LINE switch and observe printout. The relative horizontal position of dots in alternate rows should be as shown below. If either incorrect condition is observed, position the MPU arm until the dots in succeeding rows are aligned horizontally to within 0.005 inch.

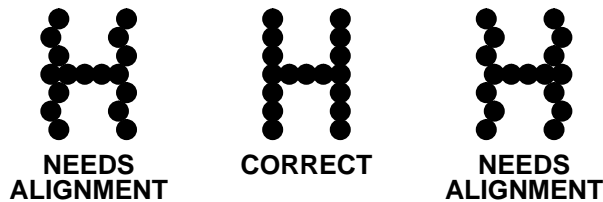

NOTE: To precisely set MPU phase, a long shanked screwdriver or Allen wrench shaft may be used as a pry bar with the bracket arms as a fulcrum.

6. Tighten screw (6). Repeat printout and readjust as necessary.
7. Install covers per paragraph 5-18b.
8. Return printer to normal operation by performing steps 10 through 13 of paragraph 5-17b.